

RD Series
Inverter / Chargers
Operator's Manual

MAGNUM
E N E R G Y

IMPORTANT SAFETY INSTRUCTIONS

This manual contains important safety instructions that must be followed during the installation and operation of this product.

To reduce the risk of electrical shock, fire, or other safety hazard, the following safety symbols have been placed throughout this manual to indicate dangerous and important safety instructions.



WARNING - Indicates a dangerous voltage or condition exists.



CAUTION - Indicates a critical step necessary for the safe installation and operation of this device.



NOTE - Indicates an important statement. Follow these instructions closely.



ATTENTION - Electrostatic Sensitive Devices. Observe precautions for handling.

All electrical work must be performed in accordance with local, state and federal electrical codes.

Read all instructions and safety information contained in this manual before installing or using this product.

This product is designed for indoor / compartment installation. It must not be exposed to rain, snow, moisture or liquids of any type.

Use insulated tools to reduce the chance of electrical shock or accidental short circuits.

Remove all jewelry such as rings, watches, bracelets, etc., when installing or performing maintenance on the inverter.

Always disconnect the batteries or energy source prior to installing or performing maintenance on the inverter.

Live power may be present at more than one point since an inverter utilizes both batteries and AC.

Always verify proper wiring prior to starting the inverter.

There are no user serviceable parts contained in this product.

SAVE THESE INSTRUCTIONS

IMPORTANT BATTERY SAFETY INSTRUCTIONS

Wear eye protection such as safety glasses when working with batteries.

Remove all jewelry such as rings, watches, bracelets, etc., when installing or performing maintenance on the inverter.

Never work alone. Always have someone near you when working around batteries.

Use proper lifting techniques when working with batteries.

Never use old or untested batteries. Check each battery's label for age, type and date code to ensure all batteries are identical.

Batteries are sensitive to changes in temperature. Always install batteries in a stable environment.

Install batteries in a well ventilated area. Batteries can produce explosive gasses. For compartment or enclosure installations, always vent batteries to the outside.

Provide at least one inch of air space between batteries to provide optimum cooling.

Never smoke when in the vicinity of batteries.

To prevent a spark at the battery and reduce the chance of explosion, always connect the cables to the batteries first. Then connect the cables to the inverter.

Use insulated tools at all times.

Always verify proper polarity and voltage before connecting the batteries to the inverter.

To reduce the chance of fire or explosion, do not short-circuit the batteries.

In the even of accidental exposure to battery acid, wash thoroughly with soap and water. In the even of exposure to the eyes, flood them for at least 15 minutes with running water and seek immediate medical attention.

Recycle old batteries.

SAVE THESE INSTRUCTIONS

Magnum Energy RD Series Inverter/Charger

Table of Contents

Section	Description	Page
1.	Introduction	1
1.	Features and Benefits	1
2.	Standard Features	1
3.	How an Inverter/Charger Works	3
4.	Appliances and Run Time	3
5.	The RD Series	5
2.	Installation	7
1.	Unpacking and Inspection	7
2.	Pre-Installation	7
	Locating the Inverter	7
	Locating Dedicated Batteries (optional)	7
	Hardware / Materials Required	8
	Tools Required	8
	Wiring	8
	AC Connections	8
	DC Connections	8
	AC Grounding	8
	DC Grounding	8
	Torque Requirements	9
	AC Main Panel	9
	Circuit Protection	9
	Wire Routing	9
3.	Installation	11
	Inverter Mounting	11
	Battery Installation	11
	Battery Cables and Sizing	12
	DC Wiring	12
	DC Grounding	12
	Negative Cable	12
	Positive Cable	12
	Battery Wiring	13
	Parallel Connection	13
	Series Connection	15
	Series/Parallel Connection	15
	DC Fuse Block	17
	AC Wiring	19
	AC Input (Shore Power) Routing	19
	AC Input (Generator) Routing	19
	Main AC Electrical Panel Routing	19
	Wiring the Inverter AC Input	21
	Wiring the Inverter AC Output	21
	Final Inspection	21

Table of Contents, continued

Section	Description	Page
2	Installation, continued	
4.	Options	25
	Battery Temperature Sensor Installation and Wiring	25
	Remote Control Installation and Wiring	25
	AGS Module	25
	Smart Shunt	25
	Stacking Cable Kit	25
5.	Start-up and Test	26
	Connecting the Batteries to the Inverter	26
	Final Inspection and Power-up	26
	Configuring the Inverter	27
3.	Operation	28
1.	Operating the Inverter	29
	Search	29
	Inverter Mode	29
	AC Shore Power Mode	29
	Bulk Charge Mode	29
	Absorption Charge Mode	29
	Float Charge Mode	29
	Battery Saver™ Mode	29
	Fault or Alarm Conditions	31
	Low Battery	31
	High Battery	31
	Overload	31
	Overtemperature	31
4.	Troubleshooting	33
1.	Basic Troubleshooting	33
5.	Preventive Maintenance	34
1.	Recommended Inverter and Battery Care	34
2.	Off-Season Storage	34
6.	Specifications	35
7.	Warranty	36

1. Features and Benefits

Congratulations on your purchase of the ME Series inverter/charger from Magnum Energy. The RD Series is a “new generation” inverter designed especially for rugged recreational vehicle usage. Powerful, yet simple to use, the Magnum Energy inverter will provide you with years of trouble-free performance so you can enjoy the all of the comforts you have come to expect from your RV, all backed by our limited 2 year (24-month warranty).

Installation is easy. Simply connect the inverter’s output to your distribution circuits or electrical panel; connect your shore power cable (AC) to the inverter’s easy-to-reach terminal block; connect the batteries, and then switch on the power. Using the optional remote control, you can easily operate your inverter from anywhere within your motor coach.

2. Standard Features

- Four Power Models (RD1824, RD2824, RD4024)
- Shelf, Bulkhead or Upside Down Mounting
- Modified Sine Wave Output
- Power Factor Corrected Charger (Sine Wave)
- RS485 Communication Port
- Remote Port
- Flash Programming
- ON/OFF Inverter-mounted Switch with LED Indicator
- 50 Amp Transfer (on Dual IN / Dual OUT Models)
- Extra Large AC Access Cover with Terminal Screw Block
- 360 degree DC Connection Terminals with Covers
- Battery Temperature Sensor - for optimum battery charging (optional)
- Aluminum Cover
- Smooth, Aesthetically Pleasing Design

The following accessories are also available for RD Series products:

Remote Control - for convenient finger tip operation

AGS Module - automatically starts and stops your generator

Smart Shunt - provides precise voltage to DC current

Stacking Cable Kit - designed to accommodate dual inverter configurations

1. INTRODUCTION



Figure 1
RD Series Inverter / Charger

3. How an Inverter/ Charger Works

An inverter takes direct current (DC) from your batteries and turns it into alternating current (AC), exactly like you use at home. It also takes alternating current when your motor coach is connected to shore power and transforms it into direct current to recharge your batteries.

There are two modes of operation associated with an inverter/charger:

Inverter Mode:

Direct current (DC) from the vehicle's batteries is transformed into alternating current (AC) for use with your household electrical appliances.

Charger Mode:

Alternating current (AC) is taken directly from shore power (or other AC sources) and passed directly to your household appliances. At the same time, the incoming AC is also converted to DC to recharge the vehicle's batteries.

4. Appliances and Run Time

The RD Series inverter/charger can power a wide range of household appliances including small motors, hair dryers, clocks and other electrical devices. As with any appliance using batteries for power, there is a certain length of time that it can run - this is called "run time." Actual run time depends on several variables including the size and the type of appliance, the type of batteries installed in your recreational vehicle, as well as the battery's capacity and age. Other factors such as the battery's state of charge and temperature can also affect the length of time your appliances can run.

Appliances such as TVs, VCRs, stereos, computers, coffee pots, incandescent lights and toasters can all be successfully powered by your inverter. Larger electrical appliances, however, such as stoves, water heaters, etc., can quickly drain your batteries and are not recommended for this application.

All electrical appliances are rated by the amount of power they consume. The rating is printed on the product's nameplate label, usually located on its chassis near the AC power cord. Even though it is difficult to calculate exactly how long an inverter will run a particular appliance, the best advice is trial and error. Your RD Series inverter has a built-in safeguard that automatically protects your batteries from over discharge.



NOTE: For optimum performance, a minimum battery bank of 200 AHr is recommended.

Device	Load	Device	Load
Blender	400 W	Coffee Maker	1200 W
Computer	300 W	Color TV	150 W
Drill	500 W	Hair Dryer	1000 W
Hot Plate	1800 W	Iron	1000 W
Light (Flo)	10 W	Light (Inc)	100 W
Microwave	1000 W	Refridgerator	500 W

Table 1 - Typical Appliance Power Consumption

1. INTRODUCTION

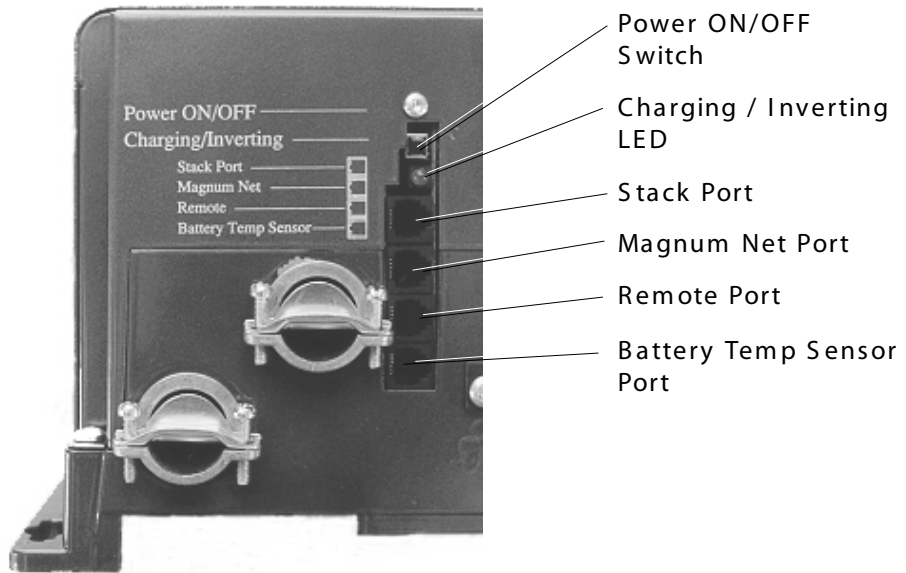

Figure 2
RD Series Inverter / Charger
Switch, LED and Connection Ports



Figure 3
RD Series Inverter / Charger
Electrical Connection Points

5. The RD Series Inverter/ Charger

The RD Series inverter/charger is designed to allow easy access to wiring, circuit breakers, controls and LED status indicator. Its die cast baseplate with one piece aluminum cover ensures maximum durability with minimum weight, as well as cooler more efficient operation. The inverter is equipped with the following features:

ON / OFF Switch - used to manually switch the inverter ON and OFF.

Green LED Indicator

- Medium flash (1 every 2 seconds)

Indicates connected loads are being powered from the batteries (inverting).

- Fast flash (1 per second)

Indicates "search" mode, conserving power when appliances are switched OFF.

- Solid

Indicates "bulk" charge when the batteries are low and the inverter is connected to shore power.

- Fast flash (1 per second)

Indicates "absorption" charge when the batteries are almost fully recharged and the inverter is connected to shore power.

- Slow flash (1 every 8 seconds)

Indicates "float" charge when batteries are fully charged and the inverter is connected to shore power.

- LED off

Indicates a "fault" condition such as low battery, overload or over temperature.

Remote Control Port - accepts connector for Magnum remote control cable.

BTS Port - accepts connector for remote battery temperature sensor cable.

MagnumNet Communication Port - accepts connector for Auto Gen Start or Smart Shunt (DC current display) cable.

Positive Battery Terminal - provides 360 degree connection point for the positive (+) cable from the vehicle's batteries.

Negative Battery Terminal - provides 180 degree connection point for the negative (-) cable from the vehicle's batteries.

Chassis Ground Connector - accepts chassis ground cable.

AC Access Cover - provides access to internal AC screw terminal connections.

AC Input Circuit Breaker - protects main AC (shore power) input circuit.

AC Output 1 Circuit Breaker (optional) - protects the primary AC output circuit (on dual out units only).

AC Output 2 Circuit Breaker (optional) - protects secondary AC output circuit (on dual out units only).

RD Series Nameplate Label - provides product and safety information.

2. INSTALLATION

this page left blank

1. Unpacking and Inspection

Carefully remove the RD Series inverter from its shipping container and inspect all contents. If items appear to be missing or damaged, contact Magnum Energy at (425) 353-8833 or your authorized Magnum Energy dealer. If at all possible, retain the shipping container in the event the unit ever needs to be returned for factory service.



ATTENTION: Electrostatic Sensitive Devices. Observe precautions for handling.

2. Pre-Installation

Before installing the inverter, read all of the instructions and cautionary markings contained in this manual.



NOTE: The inverter is heavy. Use proper lifting techniques during installation to prevent personal injury.

Locating the Inverter

The inverter must be mounted in a clean, dry, ventilated environment where the ambient temperatures will not exceed 122 °F (50 °C). The location must be fully accessible and protected from exposure to heat producing devices. You can mount the inverter horizontally, vertically or upside-down. It must be securely fastened to a shelf, bulkhead, or other structural part.

Allow enough clearance to access the AC and DC connection points as well as the inverter's controls and status indicator. As with any inverter, it should be located as close to the batteries as possible. Longer battery cable runs tend to loose efficiency and reduce the overall performance of an inverter.

Locating Dedicated Batteries (optional)

Dedicated batteries must be mounted in a clean, dry, ventilated environment where they are protected from high and low temperatures. The batteries must be mounted upright (if using liquid batteries). The location must be fully accessible and protected from exposure to heat producing devices.

To ensure optimum performance, a ventilated battery enclosure is recommended. The batteries should be located as close as possible to the inverter. Longer battery cable runs tend to loose efficiency and reduce the overall performance of an inverter. Also, do not mount the batteries beneath the inverter (or in the same compartment). Batteries emit corrosive fumes which could damage the inverter's electronics.



NOTE: For optimum performance, Magnum Energy recommends using AGM (absorbed glass mat) batteries such as Lifeline™ brand batteries.

2. INSTALLATION

2. Pre-Installation, continued

Hardware / Materials Required

Conduit, strain-reliefs and appropriate fittings
1/4" mounting bolts and lock washers
Electrical tape
Wire ties

Tools Required

Misc screw drivers	Level	1/2" wrench
Drill and drill bits	Pliers	Wire strippers
Level	Pencil or Marker	Multimeter

Wiring

Pre-plan the wire and conduit runs. For maximum safety, run both AC and DC wires/cabling in (separate) conduit. Direct current wiring, due to its potential to generate RFI, should be tied together with electrical tape. Wiring and installation methods must conform to all applicable electrical codes.



NOTE: Run DC cabling in twisted pairs, keeping the runs as short as practical.

AC Connections

Use # 10 AWG (or larger) THHN wire for all AC wiring. The inverter's AC terminal blocks accept up to # 6 AWG wire.

DC Connections

Battery to inverter cabling should be only as long as required. If using # 2/0 AWG cables, do not exceed 5 feet (one way) for 12 VDC systems.

Crimped and sealed copper ring terminal lugs with a 5/16" hole should be used to connect the battery cables to the inverter's DC terminals.

AC Grounding

The AC Ground connection located in the AC compartment must be wired to the main AC Ground of the distribution panel.



DC Grounding

The inverter/charger should always be connected to a permanent, grounded wiring system. For the majority of installations, the negative battery conductor is bonded to the vehicle's safety-grounding conductor (green wire) at only one point in the system. The size for the conductor is usually based on the size of the largest conductor in the DC system. DO NOT connect the battery negative (-) cable to the vehicle's safety ground. Connect it only to the inverter's negative battery terminal. If there are any non-factory installed DC appliances on board the vehicle, DO NOT ground them at the safety ground. Ground them only at the negative bus of the DC load center (as applicable).

2. Pre-Installation, continued

Torque Requirements

Torque all AC wiring connections to 16 inch pounds. Torque DC cable connections to 10-12 foot pounds.

AC Main Panel

If the installation will be powering a wide-range of appliances throughout the vehicle, an AC main panel is often recommended. This is similar in appearance and function as your home's circuit breaker panel, providing an additional level of control and protection for the various circuits. Always refer to electrical codes for safe wiring practices.

Circuit Protection

If using a AC main panel for distribution, always use breakers that provide the correct ampere branch circuit protection in accordance with the National Electric Code. The breakers must also be properly rated for the appliances that will be powered.



NOTE: Both AC and DC disconnects / overcurrent protection must be provided as part of the installation.

Wire Routing

Determine all wire routes throughout the vehicle both to and from the inverter. Conductors that are at risk to physical damage must be protected by conduit, tape, or placed in a raceway. Conductors passing through walls, bulkheads or other structural members must be protected to minimize insulation damage such as chafing. During the installation, always avoid placing conductors near sources of chafing caused by vibration or constant rubbing.



CAUTION: Always check for existing electrical, plumbing or other areas of potential damage prior to making cuts in structural surfaces, bulkheads or walls.

Typical routing scenarios are:

- AC Input wiring from the shore power source to the inverter
- AC Input wiring from a generator (optional) to the inverter
- DC Input wiring from the batteries to the inverter
- AC Output wiring from the inverter to the coach's AC main panel or to dedicated circuits
- Battery Temperature Sensor cable (optional) from the inverter to the batteries
- Remote Control cable (optional) to the inverter
- Ground wiring from the inverter to an external vehicle ground

2. INSTALLATION

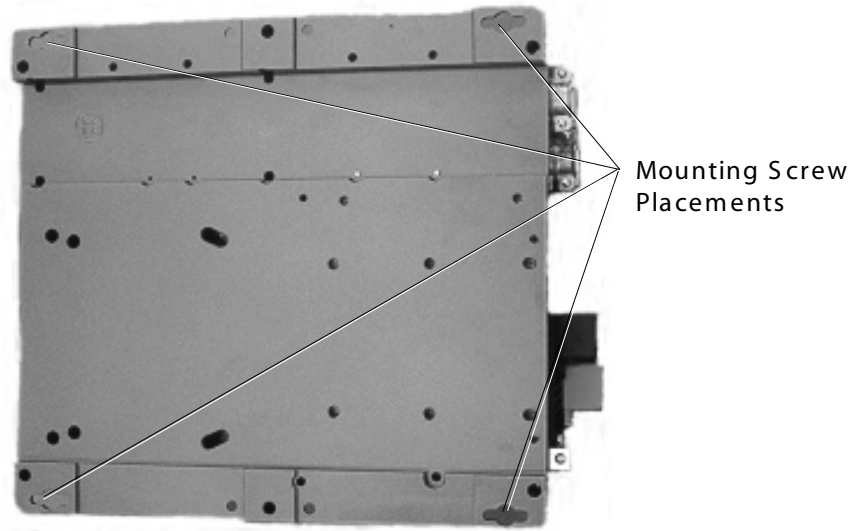

Figure 4
RD Series Inverter / Charger Base Plate

Inverter	RD1824	RD2824	RD4024
DC Rating	90 amps	140 amps	180 amps
@ 1 to 3 ft	# 2/0 AWG	# 2/0 AWG	# 4/0 AWG
@ 3 to 5 ft	# 4/0 AWG	# 4/0 AWG	# 4/0 AWG
@ 5 to 10 ft	# 4/0 AWG	# 4/0 AWG	# 4/0 AWG

Table 2 - Recommended Battery Cable Sizing

3. Installation



NOTE: Read all instructions and cautionary markings located at the beginning of this manual and in the pre-installation section, before installing the inverter and batteries.



CAUTION: Do not mount the inverter or the batteries near the vehicle's gasoline or propane fuel tanks.

Mount the inverter only on a "non-combustable" surfaces.

Maximum ambient temperature **MUST NOT** exceed 113 °F (45 °C).

For Canadian installations, the inverter's vents must face downward.

Inverter Mounting

Position the inverter in the designated mounting location horizontally, vertically or upside-down. Allow enough clearance to access the AC and DC connection points as well as the inverter's controls and status indicator. Also allow for air flow in to and around the inverter, especially near the cooling fans (approximately 3").

Mark the mounting holes in the base of the inverter's chassis. Remove the inverter and drill pilot holes into the mounting surface.

Secure the inverter to the mounting surface using appropriate screws and lockwashers.

Remove the inverter's AC access panel in accommodate the AC Input and Output wiring and conduit.

Battery Installation



NOTE: To ensure the best performance from your inverter system, do not use old or untested batteries. Batteries must be of the same size, type, rating and age.



NOTE: For optimum performance, Magnum Energy recommends using AGM (absorbed glass mat) batteries such as Lifeline™ brand batteries.



NOTE: If using Flooded Lead Acid batteries, they must be mounted upright.



CAUTION: Install batteries in a well ventilated area. Batteries can produce explosive gasses. For compartment or enclosure installations, always vent batteries to the outside.

Place the batteries as close as practical to the inverter, preferably in an insulated and ventilated enclosure. Allow adequate space above the batteries (+/- 6" above the batteries) to access the terminals and vent caps (as applicable). Also allow at least 1" of space between the batteries to provide good air flow. **DO NOT** mount the batteries directly under the inverter.

Secure the batteries to the mounting surface with battery hold down clamps.

2. INSTALLATION

3. Installation, continued

Battery Cables and Sizing

Select the correct battery cables for the installation from the table. It is important to use the correct cable to achieve maximum efficiency from the system and reduce fire hazards associated with overheated cables. Undersized cables can also lower the inverter's peak output voltage as well as reduce its surge power capability. Long cable runs also reduce efficiency due to resistance in the cable. Always keep your cable runs as short as practical.

Battery cables must be color coded with colored tape or heat shrink tubing: RED for positive (+); BLACK for negative (-); and GREEN for DC ground.

The cables must have soldered and crimped lugs, crimped copper compression lugs, or aluminum mechanical lugs. Soldered connections alone are not acceptable for this application.

DC Wiring

Refer to the safety information at the beginning of the manual before proceeding. DC wires and cables should be tied together with wire ties or electrical tape approximately every 6 inches.



WARNING: De-energize all sources of power including batteries (DC), shore power (AC), and AC generator (if applicable).



CAUTION: Inverter is NOT polarity protected. Verify proper polarity BEFORE connecting the battery cables.



NOTE: DO NOT connect the battery cables to the inverter until all wiring is complete and the correct DC voltage and polarity has been verified.



NOTE: Make sure cables have a smooth bend radius and do not become kinked. Place long cable runs in conduit and follow existing wire runs where possible.

DC Grounding

Route a grounding cable (GREEN) from the inverter's ground lug to a dedicated vehicle ground.

Negative Cable

Route a negative cable (BLACK) from the house battery bank (or dedicated battery compartment) to the inverter's negative terminal

Positive Cable

Route a positive cable (RED) from the house battery bank (or dedicated battery compartment) to the Fuse Block assembly (DC Disconnect). The DC disconnect is usually located next to or near the batteries. DO NOT connect the positive cable to the batteries at this time.

Route a positive cable (RED) from the Fuse Block assembly (DC Disconnect) to the inverter's positive terminal DO NOT connect the positive cable to the inverter at this time.

3. Installation, continued

Battery Wiring



WARNING: During the installation and wiring process, cover exposed battery cable ends with electrical tape to prevent shorting the cables.



NOTE: DO NOT connect the positive cable to the inverter at this time.

Depending upon the type of battery you use in the installation (6 or 12 VDC), the batteries must be wired in series, parallel or series/parallel to provide 12 VDC. The interconnecting battery cables must be sized and rated exactly the same as those that used to connect the inverter.

When connecting the cable to the battery terminal, hardware should be installed in the following order: bolt, ring washer, cable lug, (battery terminal), ring washer, lock washer, nut. Tighten terminal connections to at least 10 to 12 foot pounds.

When two cables are connected to a terminal (i.e., negative terminal), the hardware should be installed in the following order: bolt, ring washer, DC negative cable lug, inverter negative cable lug, (battery terminal), ring washer, lock washer, nut.

Series Connection

(multiple 6 VDC batteries to create a 24 VDC string)

A parallel connection combines overall battery capacity by the number of batteries in the string. Even though there are multiple batteries, the voltage remains the same. In the example on the next page (Figure 7), four, 6 VDC, 220 AHr batteries are combined into a single string, resulting in a 24 VDC, 220 AHr bank.

Connect the positive battery terminal to the next battery's negative terminal repeating the step for the next 2 batteries.

Connect the negative battery cable (BLACK) from the inverter to the negative terminal of the end battery.

Connect the positive (RED) battery cable from the inverter to the positive terminal of the battery at the opposite end of the string.



NOTE: A fuse must be placed between the positive terminal and the positive (RED) battery cable to the inverter.

Once the batteries are completely wired and tested, coat the terminals with an approved anti-oxidizing spray.

Nut - Washer - Lug - Terminal - Washer - Bolt

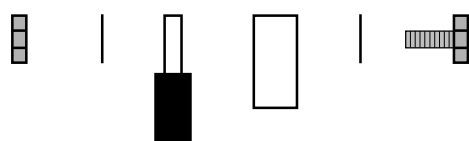

Figure 5

Battery Hardware Installation

Nut - Washer - Lug - Inverter Terminal

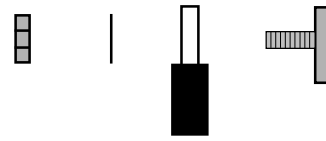

Figure 6

Inverter Hardware Installation

2. INSTALLATION

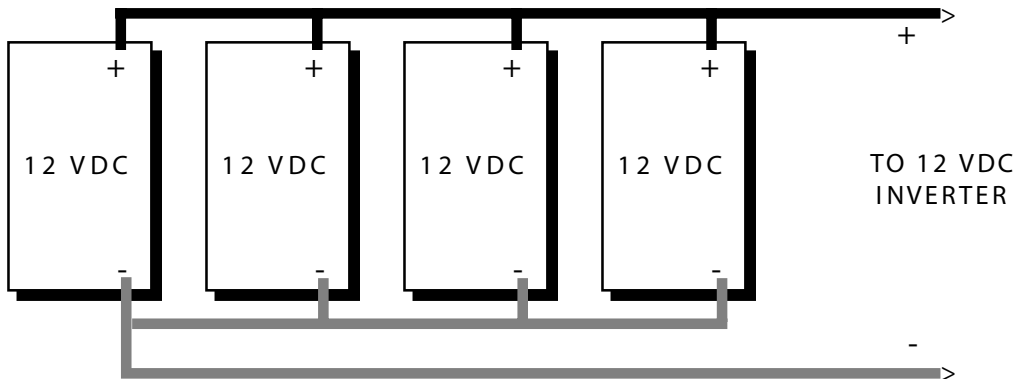

Figure 7
Parallel Battery Wiring
individual battery capacity = 100 AHr @ 12 VDC
combined battery capacity = 400 AHr @ 12 VDC

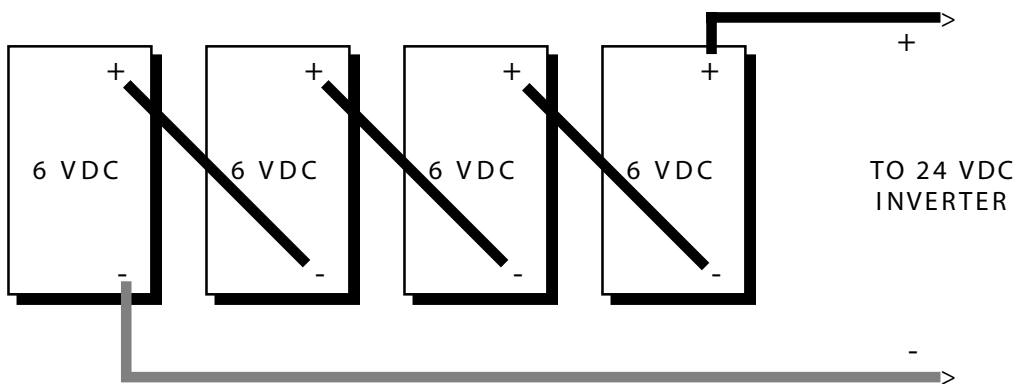

Figure 8
Series Battery Wiring
individual battery capacity = 200 AHr @ 6 VDC
combined battery capacity = 200 AHr @ 24 VDC

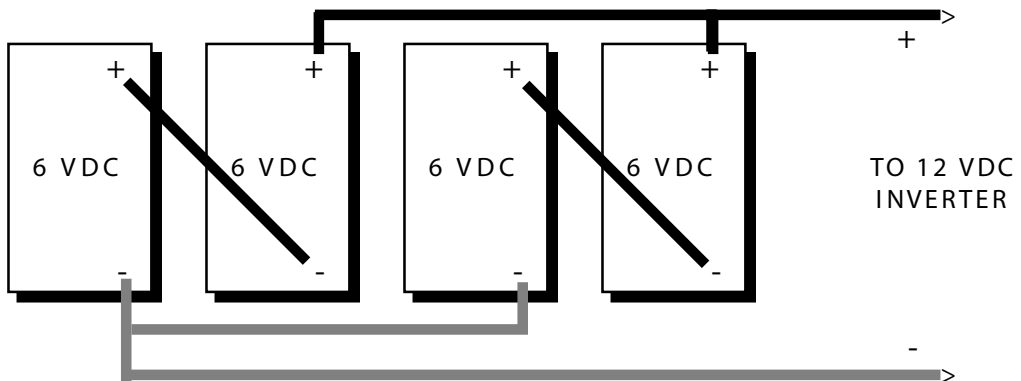

Figure 9
Series/Parallel Battery Wiring
individual battery capacity = 220 AHr @ 6 VDC
combined battery capacity = 400 AHr @ 12 VDC

3. Installation, continued

Series Connection

(four 6 VDC batteries to create a 24 VDC bank)

A series connection combines overall battery voltage by the number of batteries in the string. Even though there are multiple batteries, the capacity remains the same. In the example at the left (Figure 8), four 6 VDC, 100 AHR batteries are combined into a single string resulting in a 24 VDC, 200 AHR bank.

Connect the negative battery terminal of one battery to the positive of the other using a short cable.

Connect the negative battery cable (BLACK) from the inverter to the open negative terminal of one of the batteries. At the same time, connect a DC ground cable between the negative terminal and the vehicle's DC grounding bus.

Connect the positive battery cable (RED) from the inverter to the positive terminal of the opposite battery.



NOTE: A fuse must be placed between the positive terminal and the positive (RED) battery cable to the inverter.

Once the batteries are completely wired and tested, coat the terminals with an approved anti-oxidizing spray.

Series/ Parallel Connection

(four 6 VDC batteries to create a 12 VDC bank)

A series/parallel connection increases both voltage and capacity using smaller, lower-voltage batteries. In the example at the left (Figure 9) four 6 VDC, 200 AHR batteries are combined into two pairs resulting in a 12 VDC, 400 AHR bank.

Connect the negative battery terminal of one 6 VDC battery to the positive of the next (creating a pair) using a short battery cable.

Connect the negative battery terminal of another 6 VDC battery to the positive of its next using a short battery cable (creating a second pair).

Connect the remaining negative battery terminal of the first pair to that of the second pair using a short battery cable.

Connect the remaining positive battery terminal of the first pair to that of the second pair using a short battery cable.

Connect the negative battery cable (BLACK) from the inverter to the end battery's negative terminal. At the same time, connect a DC ground cable between the negative terminal and the vehicle's DC grounding bus.

Connect the positive battery cable (RED) from the inverter to the opposite end battery's positive terminal.



NOTE: A fuse must be placed between the positive terminal and the positive (RED) battery cable to the inverter.

Once the batteries are completely wired and tested, coat the terminals with an approved anti-oxidizing spray.

2. INSTALLATION

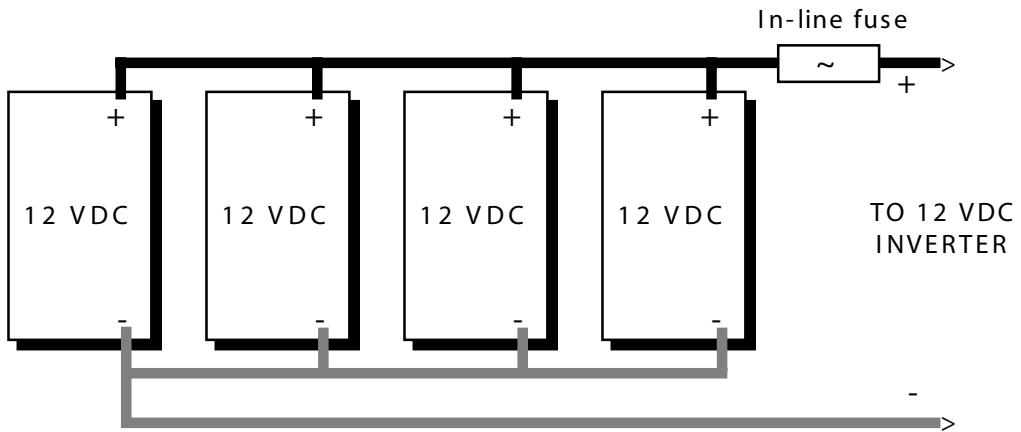

Figure 10
Parallel Battery Wiring - Fuse Placement

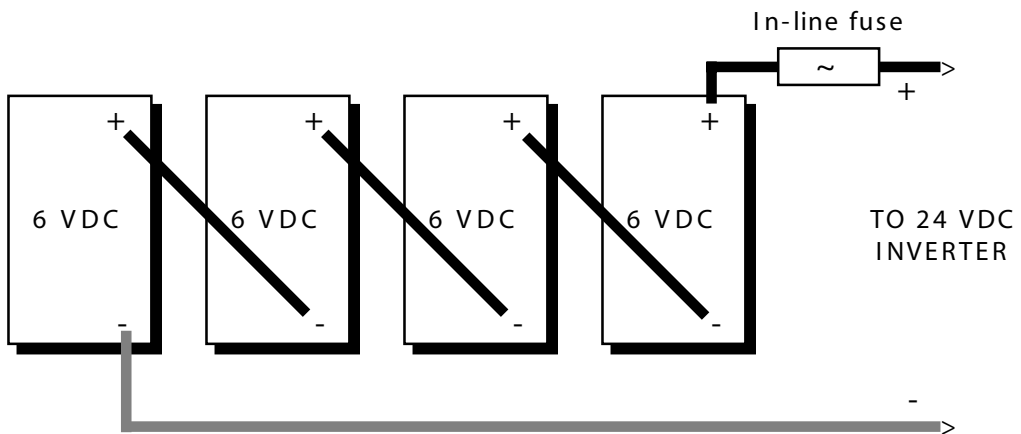

Figure 11
Series Battery Wiring - Fuse Placement

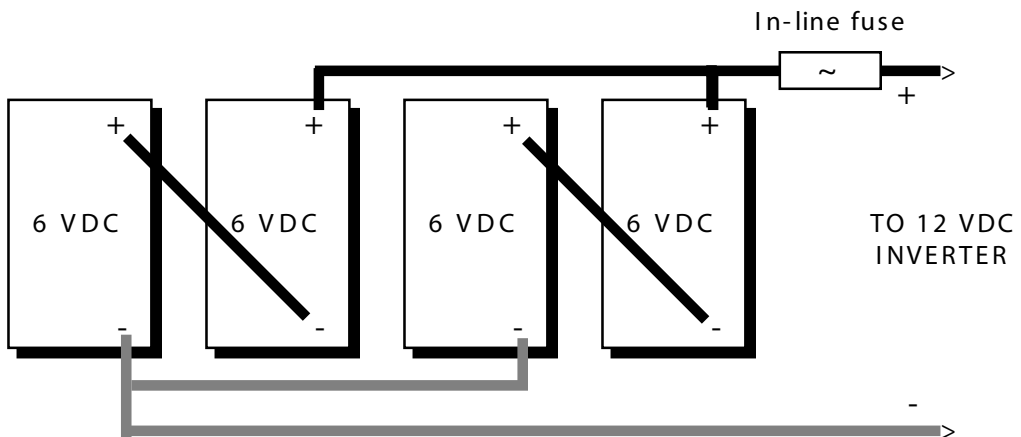

Figure 12
Series/Parallel Battery Wiring - Fuse Placement

3. Installation, continued

DC Fuse Block

A fuse or circuit breaker must be located within 18 inches of the battery to protect the DC wiring system. The device must be rated to match the size of the cable, but can be rounded up to the next larger size (i.e., a cable rated at 150 amps can accept a 175 amp fuse) as necessary.

Mount the fuse block (or circuit breaker assembly) as near as practical to the batteries.

Remove the fuse (or open the circuit breaker) and connect a short cable (same rating as the battery cables) to one end of the fuse block.

Connect the short cable to the positive battery terminal.

Connect the positive cable (RED) from the inverter to the assembly. DO NOT connect the positive cable to the inverter at this time.

Securely tighten the fuse block's lugs. Once the entire installation is complete, reinsert the fuse into the fuse block before connecting the positive cable to the inverter.

Conductor Size	# 2 AWG	# 2 / 0 AWG	# 4 / 0 AWG
Rating (conduit)	115 A max	175 A max	250 A max
Rating (free air)	170 A max	265 A max	360 A max
Breaker	N/A	DC175	DC250
Fuse	200 A	300 A	400 A

Table 3 - DC Fuse Rating

2. INSTALLATION

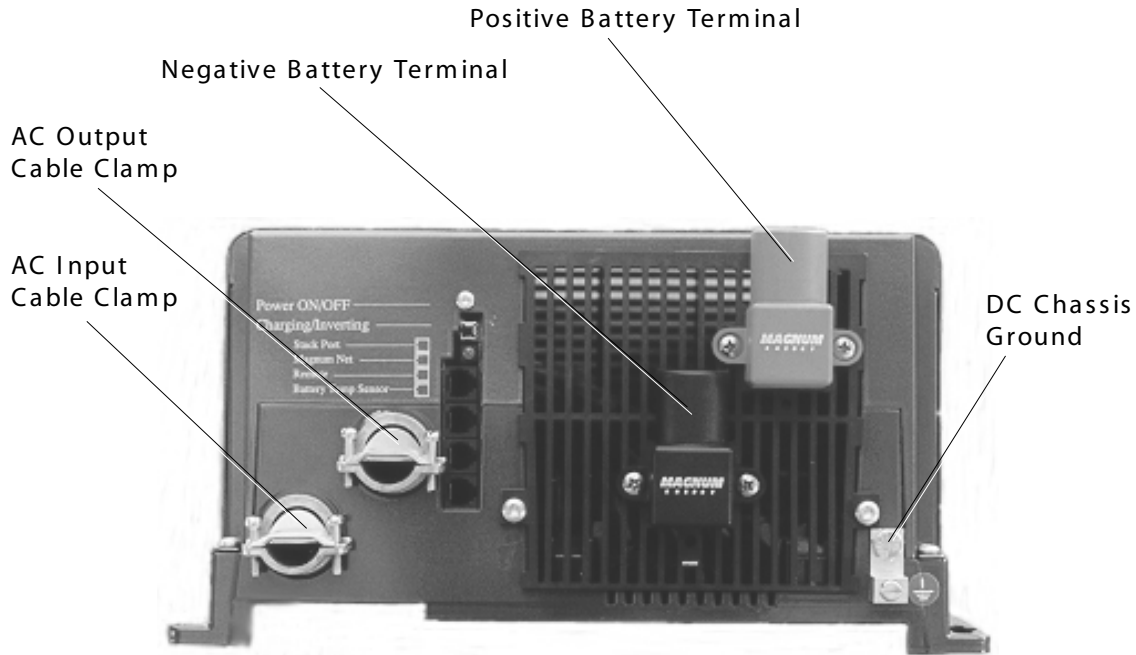

Figure 13
RD Series Inverter / Charger - AC Wiring

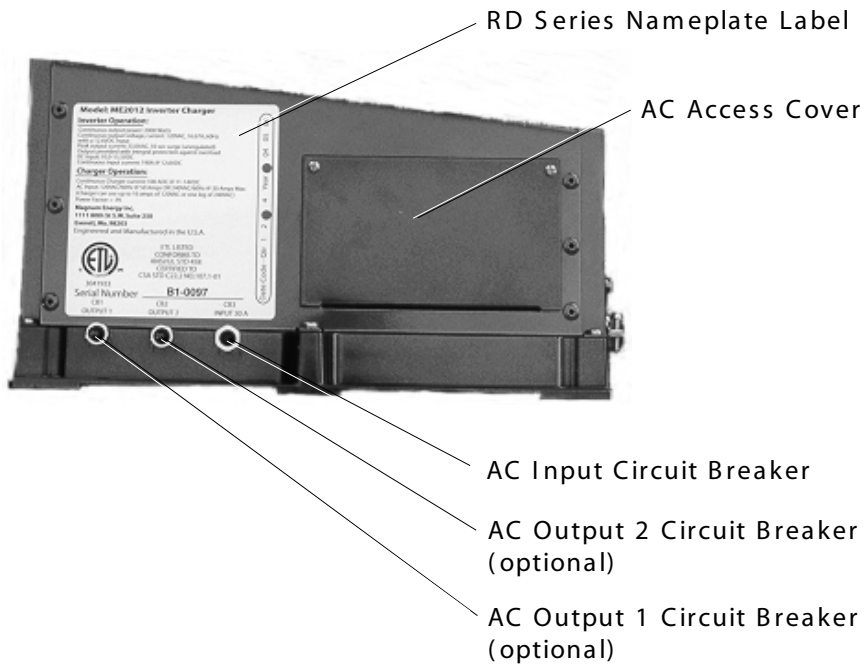

Figure 14
RD Series Inverter / Charger - AC Wiring (Access Panel)

3. Installation, continued

AC Wiring



WARNING: De-energize all sources of power including batteries (DC), grid power (AC), and AC generator (if applicable).

AC wiring must be performed by a qualified person or licensed electrician.

DO NOT connect the inverter's output to an AC power source.



WARNING: Risk of electric shock. Use only the ground-fault circuit interrupter [receptacles(s) or circuit breaker(s)] specified in the installation and operating instructions manual supplied with the inverter. Other types may fail to operate properly when connected to this inverter equipment.

Ground-fault circuit interrupters must be installed in the vehicle's wiring system to protect all branch circuits.



CAUTION: DO NOT place AC cabling in the same conduit with DC cabling.



NOTE: Read all instructions and cautionary markings located at the beginning of this manual and in the pre-installation section, before installing the inverter and batteries.

The minimum wire size for all RD Series models must be # 10 AWG. The installer must provide the appropriate circuit protection for the wire size used.

Refer to appropriate electrical codes for wire sizing and circuit protection.

AC Input (Shore Power) Routing

Route a 30 amp service (grid power) to the inverter. If the installation includes a generator, route a 30 amp service (shore power) to an approved selector switch and then to the main AC panel.

AC Input (Generator) Routing

Route a 30 amp service (generator) to an approved selector switch and then to the main AC electrical panel.

Main AC Electrical Panel Routing

Route the AC Output from the inverter's internal terminal block to the 30 amp breaker in the sub panel.

Inverter	ME1512	ME2012	ME2512
Power Rating	1800 Watts	2800 Watts	4000 Watts
Input Breaker	30 A	30 A	30 A
Input Wiring	# 10 AWG	# 10 AWG	# 10 AWG
Output Wiring	# 10 AWG	# 10 AWG	# 10 AWG

Table 4 - Recommended AC Wire Ratings for 120 VAC Applications

2. INSTALLATION

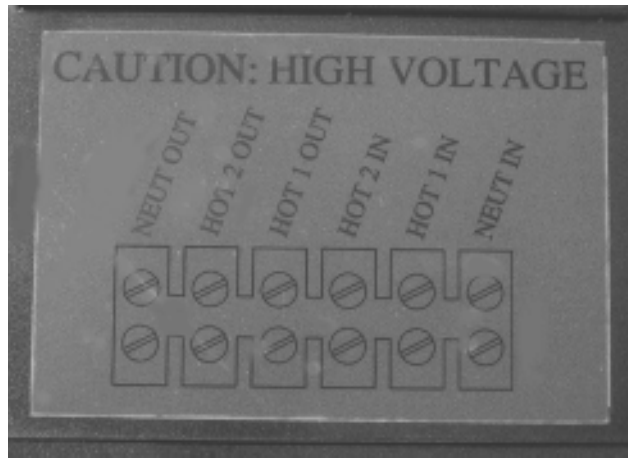

Figure 15
RD Series Inverter / Charger - AC Wiring Diagram
(located on back of cover plate)

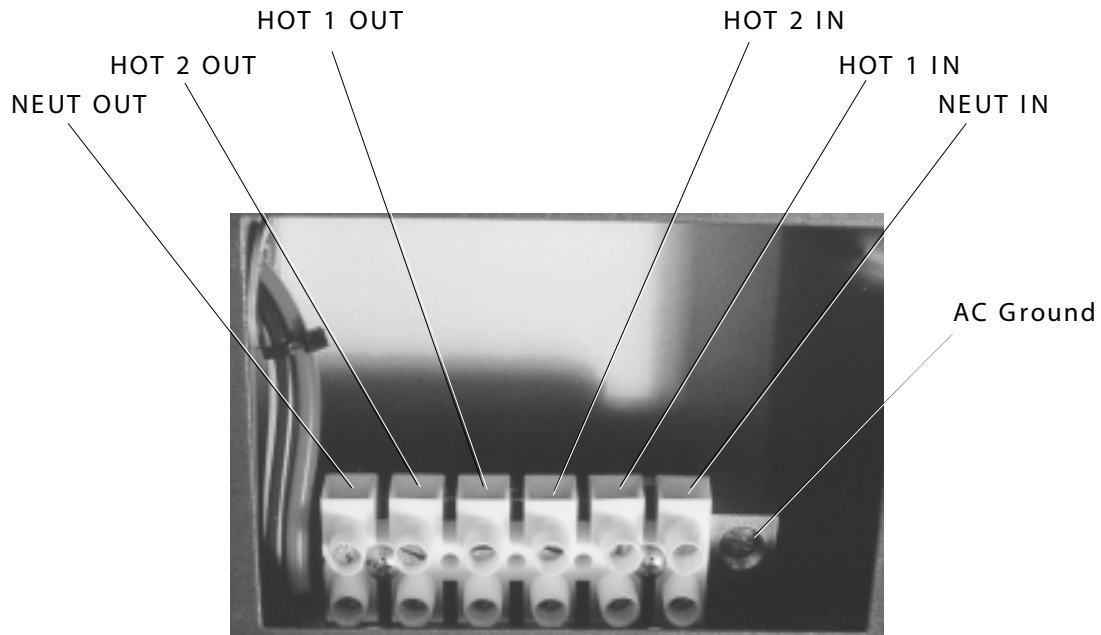

Figure 16
RD Series Inverter / Charger - AC Terminal Block

3. Installation, continued

Wiring the Inverter AC Input (refer to diagrams on the following pages)

Remove the chassis AC access cover to access the internal terminal block.

Route the cable and conduit from the main panel, approved bypass selector switch or main AC panel to the inverter's AC INPUT conduit clamp. Tighten the clamp securely on the conduit. Always leave a little extra slack in the wiring.

Connect the hot wire (BLACK) from the main panel's dedicated 30 amp breaker to the "AC INPUT (HOT 1 IN)" terminal. Tighten the screw terminal to 16 inch-pounds.



NOTE: If using dual inputs, connect the RED wire from the main panel to AC INPUT (HOT 2 IN)

Connect the neutral (WHITE) from the main panel's neutral bus bar to the "AC INPUT (NEU)" terminal. Tighten the screw terminal to 16 inch-pounds.

Connect the ground (GREEN) wire from the main panel's neutral bus bar to the "GROUND" terminal. Tighten the terminal to 16 inch-pounds.

Wiring the Inverter AC Output (refer to diagrams on the following pages)

Route the cable and conduit from the AC distribution panel to the inverter's AC OUTPUT conduit clamp. Tighten the clamp securely on the conduit.

Connect the hot (BLACK) wire to the "AC OUTPUT 1 (HOT)" terminal. Tighten the terminal to 16 inch-pounds.



NOTE: If using dual outputs, connect the RED wire to the "AC OUTPUT 2 (HOT)" terminal.

Connect the neutral (White) wire to the "AC OUTPUT (NEU)" terminal. Tighten the terminal to 16 inch-pounds.

Connect the ground (Green) wire to the "GROUND" terminal. Tighten the terminal to 16 inch-pounds.

Final Inspection

Verify all cables / conduit runs are secured with wire ties or other nonconductive fasteners to prevent chafing or damage from movement and vibration.

Verify strain reliefs or grommets are in place to prevent damage to the wiring or conduit where it passes through walls, bulkheads or other openings.

Verify all AC connections are correct and torqued to 16 inch pounds.

Replace the covers on the main electrical / distribution panel.

Replace the chassis access cover.

Verify the inverter's front panel switch is in the "OFF" position.



NOTE: If required by code, have the installation inspected by an electrical inspector.

2. INSTALLATION

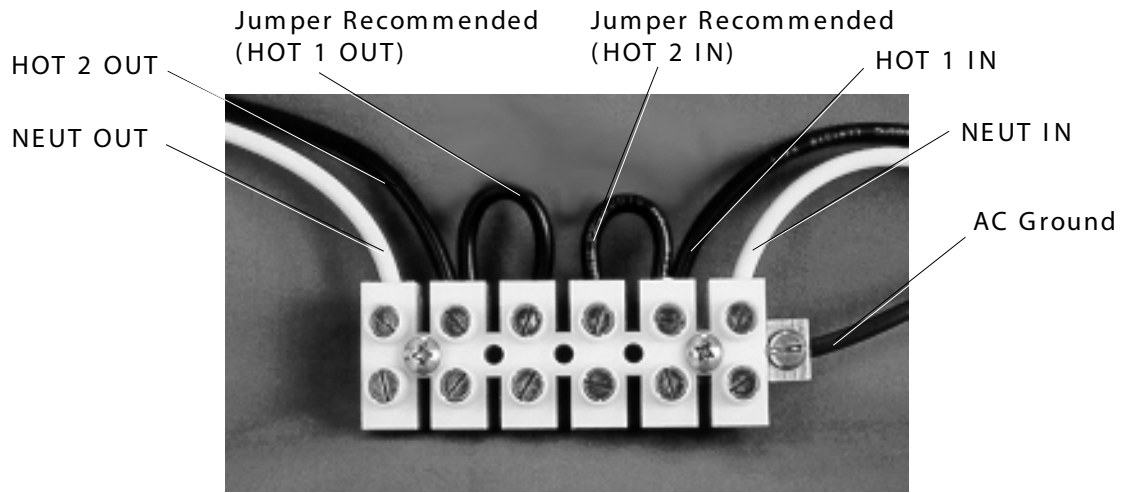

Figure 17a
Typical Wiring - Single IN / Single OUT (120 VAC)

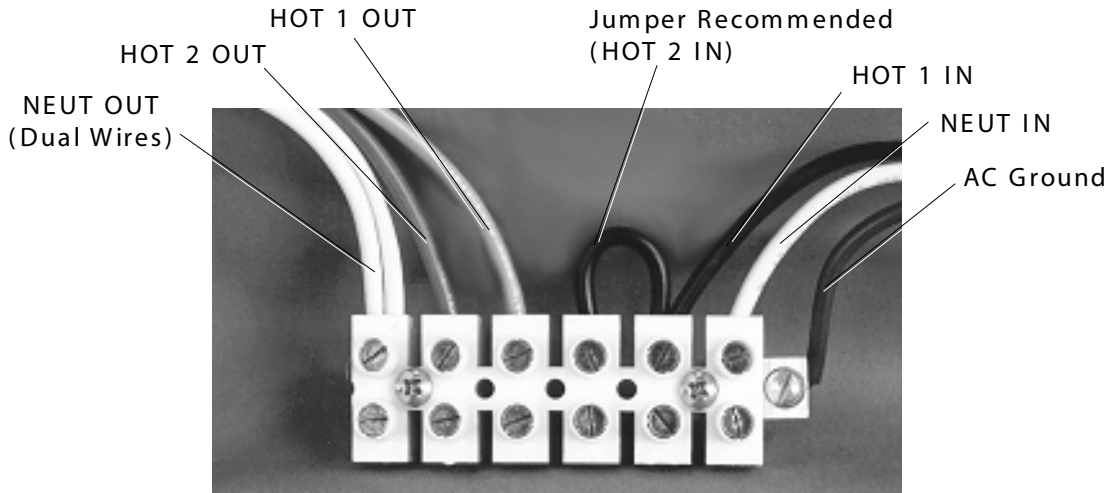

Figure 18a
Typical Wiring - Single IN / Dual OUT (120 VAC)

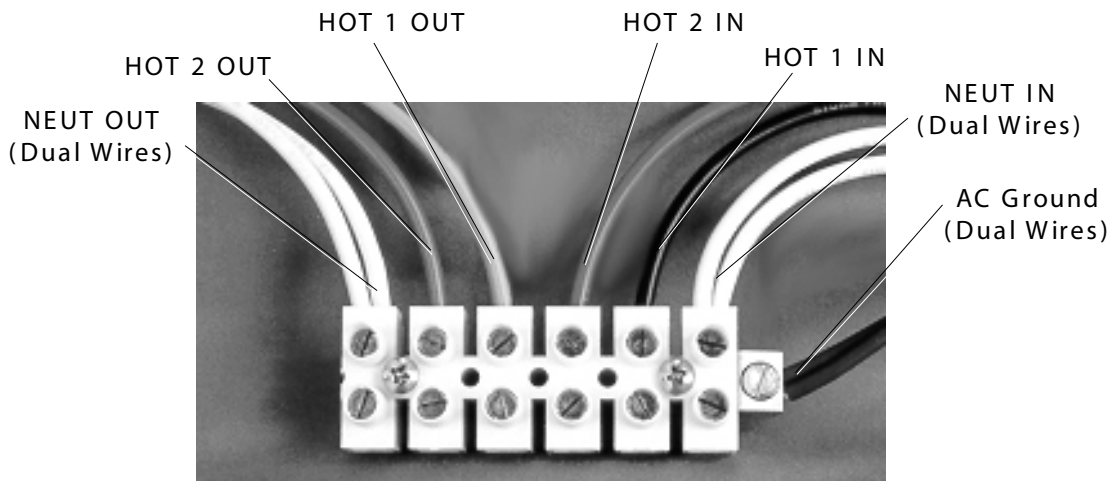

Figure 19a
Typical Wiring - Dual IN / Dual OUT (120 VAC / 240 VAC)

2. INSTALLATION

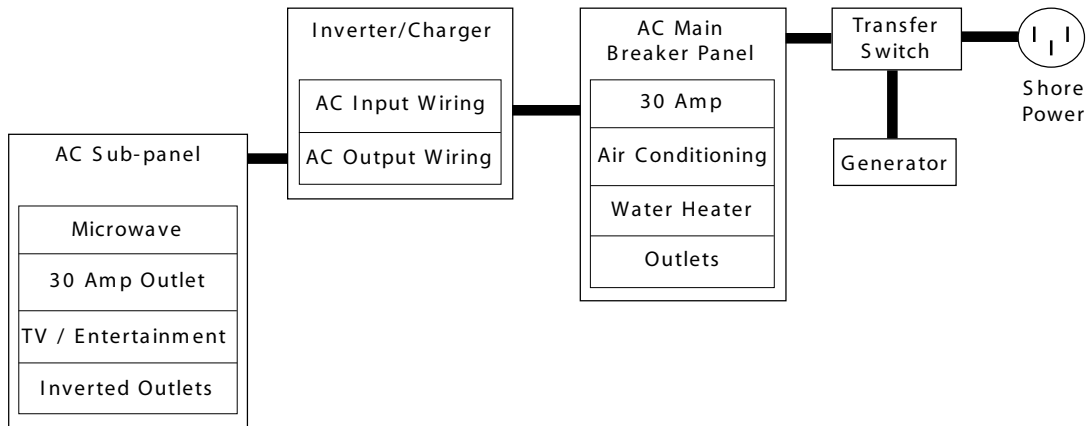

Figure 17b
Typical Wiring - Single IN / Single OUT (120 VAC)

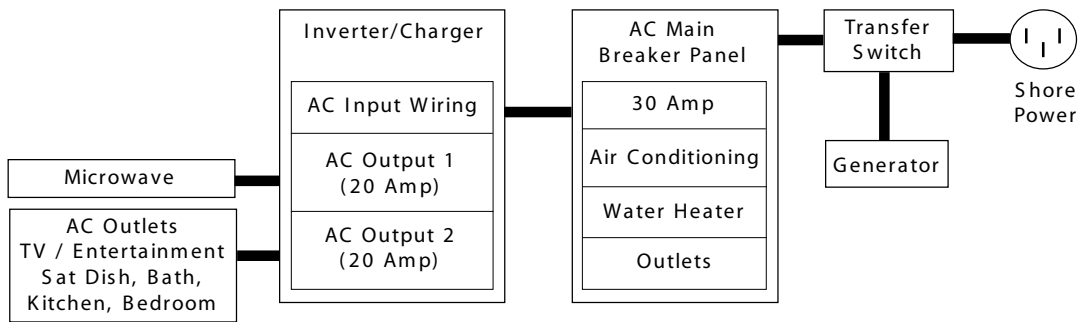

Figure 18b
Typical Wiring - Single IN / Dual OUT (120 VAC)

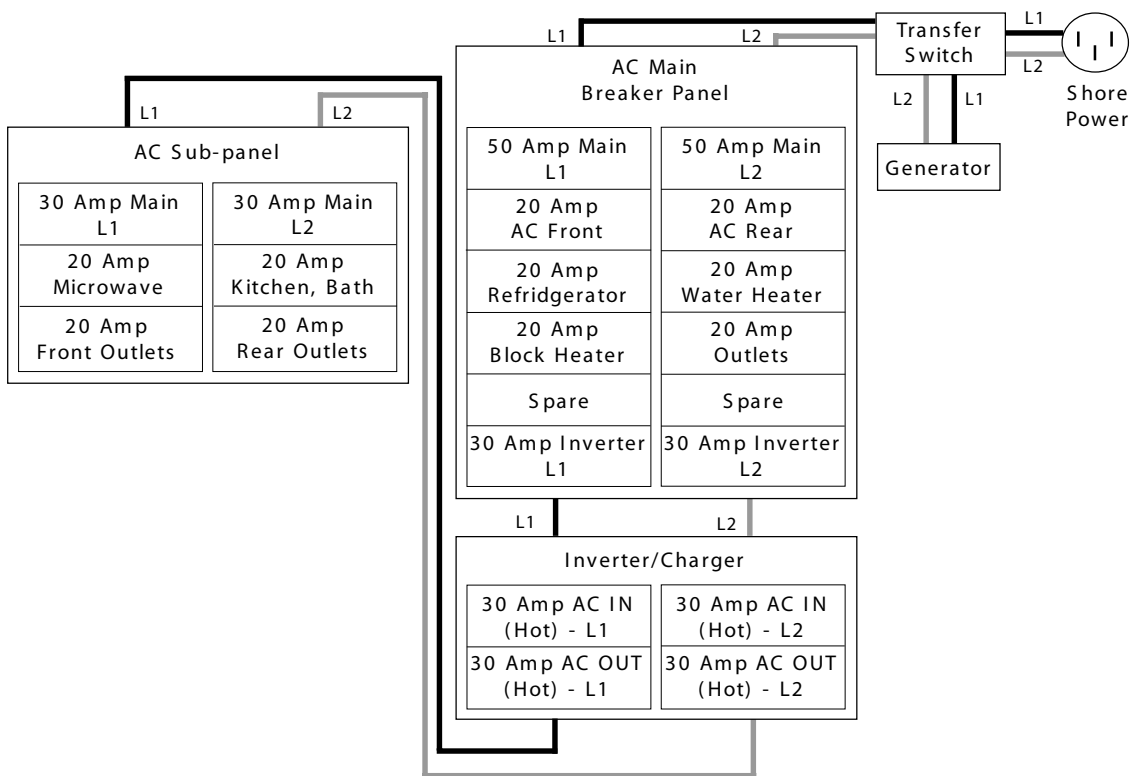

Figure 19b
Typical Wiring - Dual IN / Dual OUT (120 VAC / 240 VAC)

2. INSTALLATION

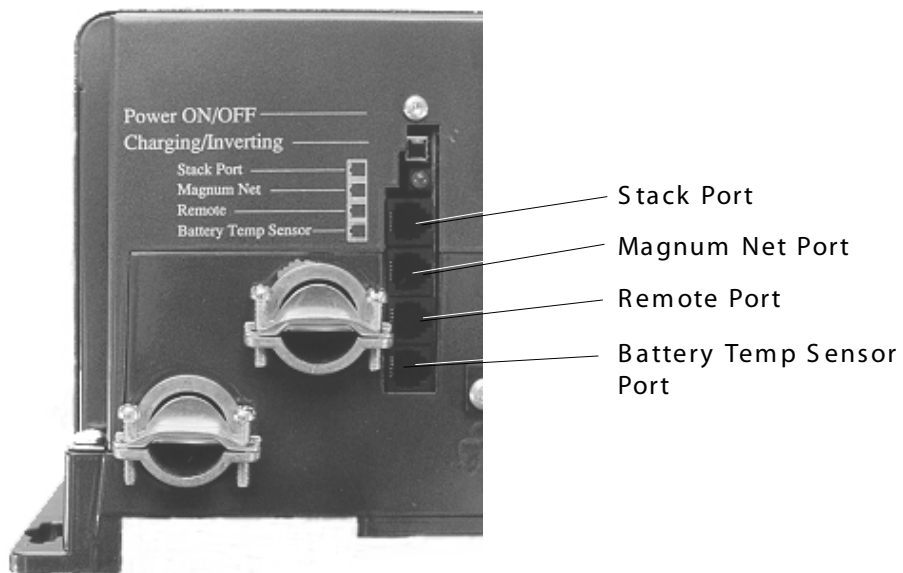

Figure 20
RD Series Inverter / Charger - Option Connection Ports

4. Options

Battery Temperature Sensor Installation and Wiring

Attach the ring terminal end of the Battery Temperature Sensor to the negative battery terminal.

Route the sensor's cable to the inverter following existing wire runs.

Connect the cable to the BTS port on the inverter's chassis.

Remote Control Installation and Wiring

Mount the remote control in a convenient location using four mounting screws (refer to the ME Series Remote Control Operator's Manual).

Route the cable to the inverter following existing wire runs.

Connect the cable to the remote port on the inverter's chassis.

AGS Module

future option - available soon

Smart Shunt

future option - available soon

Stacking Cable Kit

future option - available soon

2. INSTALLATION

5. Start-up and Test

Connecting the Batteries to the Inverter

After all electrical connections have been completed, connect the batteries to the inverter to begin the start-up process.



CAUTION: Verify correct battery voltage and polarity before connecting the cables to the inverter.

Replace the fuse or (close the breaker) at the DC disconnect.

Remove the electrical tape from the cable lugs and verify 12 VDC at the cable connectors using a multimeter. Verify correct polarity: Black is negative (-); Red is positive (+).

Connect the negative (BLACK) battery cable to the inverter's negative terminal. The cable lug must be flush to the terminal's surface. Place a lock washer and nut over the lug and torque the connection to 10 to 15 foot pounds.



NOTE: There may be a spark (and audible snap) when the cable lug first contacts the inverter's positive terminal. This is a normal condition.

Connect the positive (RED) battery cable to the inverter's positive terminal. The cable lug must be flush to the terminal's surface. Place a lock washer and nut over the lug and torque the connection to 10 to 15 foot pounds.

Verify all cables and connectors are properly secured.

Place the red and black terminal covers on the inverter's DC connector. Secure the covers with enclosed hardware.

If the batteries are in an enclosure, perform a final check of the hold down brackets and all connections. Close and secure the battery enclosure.

Final Inspection and Power-up

Prior to starting the inverter, make sure all connected appliances are switched OFF or disconnected from the AC receptacles.

Use a multimeter to verify 24 VDC at the inverter's DC connectors.

Switch the inverter power switch to ON. The inverter's LED will flash indicating DC power and the start-up sequence.



NOTE: When using the remote control, the inverter's ON/OFF switch is disabled in Charge mode.

Verify the breakers on the distribution panel are switched ON.

Use a true RMS multimeter to verify 120 VAC at the coach's AC outlets.

Connect the inverter to shore power and switch the main circuit breaker ON.

Verify the inverter's LED switches from INVERTER to AC IN (GRID POWER).

Use a true RMS multimeter to verify 120 VAC at each of the coach's AC outlets.

Switch the Shore Power OFF. Verify the inverter's LED switches to inverter mode.

5. Start-up and Test, continued

Configuring the Inverter

The RD Series inverter/charger must be configured for Low Battery Cutoff (LBCO), Shore Power Current, Charger Amps, Battery Size and Battery Type. These operational parameters must be configured using the optional remote control.

Refer to the ME Series Remote Control operator's manual to configure the following parameters:

Shore (5, 10, 15, 20, 30, 50)

AGS OFF

Enable

Meter DC

AC

Setup Search

LBCO

Battery Bank

Battery Type

Charge Rate

Contrast

Factory Reset

Tech Temps

Fault Record

The RD Series inverter/charger also allows you to select an equalize charge for the batteries. Press and hold the Charger ON/OFF switch for 4 seconds. The Equalize (EQ) function will be initiated (and the correct code will be sent to the remote.) The EQ function automatically terminates after 4 hours of operation. You can also manually stop the equalize mode by pressing and holding the Charger ON/OFF switch while the inverter is in EQ mode.

Function	Default
Search	5 watts
LBCO	22 VDC
Battery Bank	400 Ahr
Battery Type	Liquid Lead Acid
Charge Rate	100 %
Contrast	75 %

Table 5 - Factory Default Settings

3. OPERATION

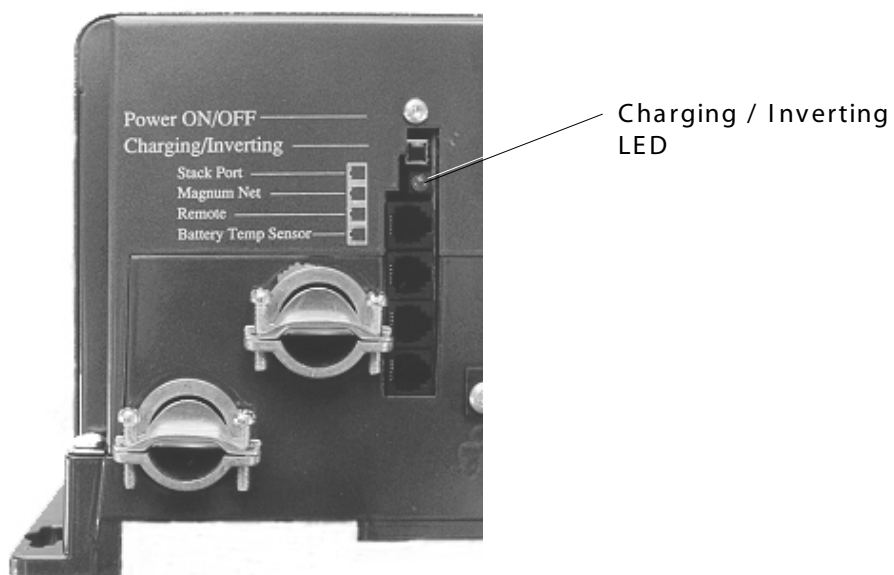

Figure 21
RD Series Inverter / Charger - LED Indicator

1. Operating the Inverter

The RD Series inverter/charger has two modes of operation: INVERTER (providing power to your appliances from the batteries) and AC (running from shore power or a generator). Whenever the inverter is in AC mode, it passes power directly to your appliances as well as recharges the batteries using a 3-stage battery charger (Bulk, Absorption and Float). This approach to battery charging provides rapid and complete charging cycles without placing undue stress on the batteries. Inverter operation is fully automatic.

Search

With search mode enabled, the inverter pulses the AC output looking for an electrical appliance (typically 5 to 100 watts, depending upon the setting you've selected). Whenever there is no load detected, the inverter automatically goes into search mode (sleep) to minimize energy consumption. During this time, the inverter's green LED flashes (fast) to indicate SEARCH mode. When an appliance is switched on inside the coach, the inverter recognizes the need for power and automatically starts the inverter.

Inverter Mode

Whenever AC Shore Power is no longer sensed, the inverter automatically transfers to battery power with no interruption to your appliances. The inverter's green LED flashes once every 2 seconds (medium flash) to indicate it is running on battery power and providing AC to the coach.

AC Shore Power Mode

Whenever AC Shore Power is sensed, the inverter automatically transfers to the shore power with minimal interruption to your appliances.

Bulk Charge Mode

Whenever the inverter is running on nominal AC Shore Power, it charges the batteries. The inverter's green LED stays ON (solid) to indicate the first stage of charging. During bulk charging, the charger supplies the maximum amount of constant current to the batteries. As the battery voltage rises to a set value (typically 28.2 VDC for GEL, 28.6 VDC for AGM, and 29.2 VDC for liquid lead acid), the charger will then switch to the next charging mode.

Absorption Charge Mode

As the inverter continues to run on nominal AC Shore Power, and the batteries have been successfully bulk charged, the charger enters its second stage of charging. The inverter's green LED flashes once every second (fast flash) to indicate absorption charging for 1 - 3 hours depending upon battery bank selection (refer to the ME Series Remote manual). The charger then switches to its final charging mode.

Float Charge Mode

As AC shore power continues, the inverter's green LED flashes once every 8 seconds (slow flash) to indicate the third and final stage of charging. The batteries are held at the float voltage (typically 13.6 VDC for GEL, 26.2 VDC for AGM, and 13.4 VDC for liquid lead acid) as long as AC is present at the inverter's input. Float charging reduces battery gassing, minimizes watering requirements (for flooded batteries) and ensures the batteries are maintained at optimum capacity.

Battery Saver™ Mode

Designed to keep batteries fully charged over long periods (storage) without drying them out. Whenever the charger is in float for 4 hours with no DC loads running, the charger will turn OFF. If the battery voltage drops below 25.0 VDC, the charger will automatically initiate float mode to return them to a full charge.

3. OPERATION

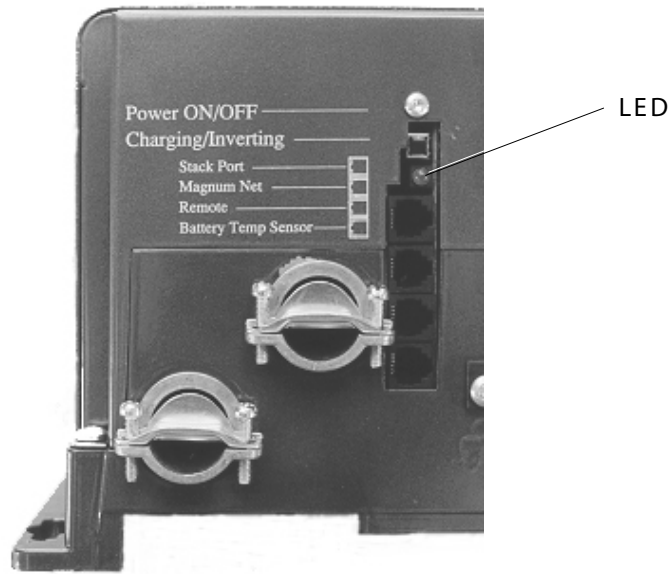

Figure 22
RD Series Inverter / Charger - Fault Conditions

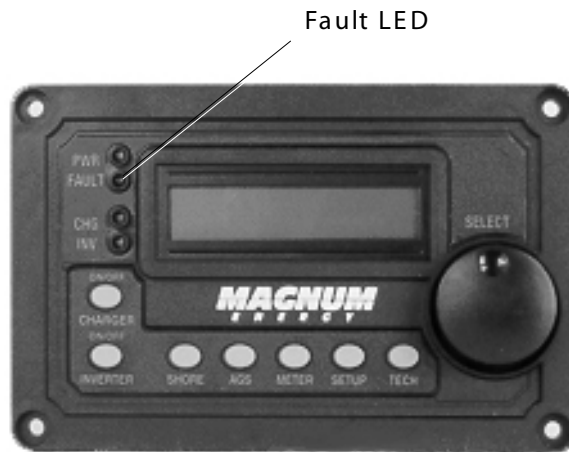

Figure 23
Optional RD Series Remote Control - Fault Conditions

1. Operating the Inverter, continued

Fault or Alarm Conditions

The inverter monitors the AC Shore Power, the batteries and itself. Whenever a condition occurs that is outside the normal operating parameters, the inverter will take the necessary steps to protect your appliances, batteries or itself from damage.

Low Battery

Whenever the battery voltage reaches a low level, the inverter will initiate Low Battery Cutoff (LBCO) which automatically shuts the inverter down, along with all connected loads, to protect the batteries from over-discharge damage. The inverter's LED turns OFF to indicate the fault condition.

High Battery

As the inverter is charging, it constantly monitors the batteries. In the event the battery voltage approaches too high of level, it automatically turns off the battery charger to protect the batteries from damage. The inverter's LED turns OFF to indicate the fault condition.



NOTE: High battery voltage may be caused by excessive voltage from the alternator, solar panels or other external charging sources.

Overload

During inverter and AC Grid Power operation, the inverter monitors the AC and DC circuits. In the event of a short-circuit or overload condition, the inverter will shut down. The inverter's LED turns OFF to indicate the fault condition.

Overtemperature

During inverter operation, if the inverter becomes overheated, it will shut down to protect itself from damage. The inverter's LED turns OFF to indicate the fault condition.

4. TROUBLESHOOTING

this page left blank

1. Basic Troubleshooting

The ME Series inverter/ charger is a fairly simple device to troubleshoot. There are only two active circuits (AC and DC) as well as a charging circuit. The following chart is designed to help you quickly pinpoint the most common inverter failures.



WARNING: De-energize all sources of power including batteries (DC), shore power (AC), and AC generator (as applicable).

Symptom	Possible Cause	Recommended Solution
No output power. Inverter LED is OFF.	Inverter is switched OFF.	Switch the inverter ON.
	Battery voltage is too low.	Check battery voltage, fuses, breakers and cable connections.
No output power. Inverter LED is OFF.	High or low battery voltage.	Check the battery voltage at the inverter's terminals.
		Discharge or charge batteries.
		Replace the batteries.
No output power. Green LED is flashing.	Load is too small for search mode circuit detection.	Reduce the search threshold or defeat search mode.
Low output power.	Low batteries.	Check and recharge batteries.
Appliances turn OFF/ ON. Green LED is flashing.	Loose or corroded battery cables.	Clean and tighten all cables.
	Low batteries.	Recharge or replace batteries.
	Loose AC output connections.	Tighten AC output connections.
AC output voltage seems too low when using a meter.	Wrong type of voltmeter used (displays 80 VAC to 100 VAC).	Use a "true" RMS voltmeter.
Low surge power.	Low batteries.	Check and recharge batteries.
	Battery cables are the wrong length or gauge.	Verify recommended cable lengths and gauges from the manual. Replace cables as necessary.
Low charging rate when connected to grid power.	Charge rate set too low.	Adjust charge rate from remote.
	Low AC voltage (< 90 VAC).	Check AC input wiring.
Low charging rate when using a generator.	Generator output is too low to power both load and charger.	Reduce the load. Increase the generator's RPMs.
Charger doesn't charge.	Loose or corroded battery cables.	Clean and tighten battery cables.
	Defective batteries.	Replace batteries.
	Wrong charger settings.	Adjust the charger settings.
	Wrong AC input voltage.	Verify proper AC input voltage and frequency.

5. PREVENTIVE MAINTENANCE

1. Recommended Inverter and Battery Care

The RD Series inverter/ charger is designed to provide you with years of trouble-free service. Even though there are no user-serviceable parts, it is recommended that every 6 months you perform the following maintenance steps to ensure optimum performance and extend the life of your batteries.



WARNING: Prior to performing these checks, switch both the AC and DC circuits OFF.

Visually inspect the batteries for cracks, leaks, or swelling - replace if necessary

Use baking soda to clean and remove any electrolyte spills or buildups

Check and tighten all battery hold down clamps

Clean and tighten (10 to 12 foot pounds) all battery terminals and connecting cables

Check and fill battery water levels (Liquid Lead Acid batteries only)

Check individual battery voltages (replace those that vary more than 0.3 VDC of each other)

Check all cable runs for signs of chafing - replace if necessary

Check the inverter's cooling vents - clean as necessary

Check and tighten (16 foot pounds) the inverter's internal AC terminal block connections

2. Off-Season Storage

When placing the coach into seasonal storage, it is recommended that you perform the following to ensure the system is properly shutdown (or properly configured for seasonal storage). This is especially important for maintaining the batteries.

Non-protected Storage

Perform the recommended maintenance steps above

Fully charge the batteries

Connect shore power and verify the breaker to the inverter is switched ON

Verify the inverter is switched ON

Switch OFF all unnecessary AC and DC loads

Protected Storage

Perform the recommended maintenance steps above

Fully charge the batteries

Switch OFF all AC and DC loads

Verify the inverter is switched OFF

Remove shore power and disable the generator (if installed)

RD Series Specifications

MODEL	RD1824	RD2824	RD4024
Input Voltage (nominal):	24 VDC	24 VDC	24 VDC
Input Voltage (range):	21.6-31.0 VDC	21.6-31.0 VDC	21.6-31.0 VDC
Power Rating @ 45°C:	1800 watts	2800 watts	4000 watts
Surge Rating:	3600 watts	5200 watts	8000 watts
Rated Power:	95 amps	142 amps	189 amps
Full Voltage:	0.750 amps	0.850 amps	0.900 amps
Search Mode:	0.025 amps	0.030 amps	0.030 amps
Short Circuit:	285 amps	475 amps	595 amps
Inverter Efficiency:	94% max	94% max	94% max
Charger Efficiency:	85% max	85% max	85% max
Charger (power factor):	> 0.95	> 0.95	> 0.95
Charge Rate (adjustable):	0-65 amps	0-80 amps	0-120 amps
Battery Protection (variable):	10-11.5 VDC	10-11.5 VDC	10-11.5 VDC
Unit Weight:	38lb (17kg)	40lb (18kg)	45lb (20kg)

Common Specifications

Output Voltage:	120 VAC	Frequency Regulation:	60 Hz \pm .04%
Voltage Regulation (max):	\pm 5%	Voltage Regulation (typ):	\pm 2.5%
Waveform:	modified sine	Power Factor:	0 to 1
Adjustable Load Sensing:	5 to 100 watts	Automatic Transfer Relay:	30 amps at 120 VAC 50 amps at 240 VAC
Remote Control:	optional	Four Stage Charging:	bulk, absorb, float and Battery Saver™
Charging Profiles:	liquid lead acid, AGM, and GEL	Temp Comp Probe:	yes (optional)
Forced Air Cooling:	variable speed fan	Remote Dry Contact:	optional pigtail (inverter on/off)
DC Load Disconnect Sensing:	on/off (high/low DC signal)		
Series Operation:	240 VAC (future)		

Environmental Characteristics

Operating Ambient Temp:	-4 °F to +120 °F (-20 °C to +50 °C)
Max Altitude (operating):	15,000 feet (4.57 km)
Dimensions (HxWxD):	13.75" x 12.65" x 8" (34.9 cm x 32.1 cm x 20.3 cm)
Mounting:	shelf (top or bottom up) or bulkhead

Specifications @ 25 °C - Subject to change without notice

7. WARRANTY

24 Month Limited Warranty

Magnum Energy, Inc., warrants the RD Series Inverter / Charger to be free from defects in material and workmanship that result in product failure during normal usage, according to the following terms and conditions:

1. The limited warranty for the product extends for 24 months beginning from the product's original date of purchase.
2. The limited warranty extends to the original purchaser of the product and is not assignable or transferable to any subsequent purchaser.
3. During the limited warranty period, Magnum Energy will repair, or replace at Magnum Energy's option, any defective parts, or any parts that will not properly operate for their intended use with factory new or rebuilt replacement items if such repair or replacement is needed because of product malfunction or failure during normal usage. The limited warranty does not cover defects in appearance, cosmetic, decorative or structural parts or any non-operative parts. Magnum Energy's limit of liability under the limited warranty shall be the actual cash value of the product at the time the original purchaser returns the product for repair, determined by the price paid by the original purchaser. Magnum Energy shall not be liable for any other losses or damages.
4. Upon request from Magnum Energy, the original purchaser must prove the product's original date of purchase by a dated bill of sale, itemized receipt.
5. The original purchaser shall return the product prepaid to Magnum Energy in Everett, WA. Magnum Energy will return the product prepaid to the original purchaser after the completion of service under this limited warranty.
6. This limited warranty is voided if:
 - the product has been modified without authorization
 - the serial number has been altered or removed
 - the product has been damaged through abuse, neglect, accident, high voltage or corrosion.
 - the product was not installed and operated according to the owner's manual.

IN CASE OF WARRANTY FAILURE, CONTACT MAGNUM ENERGY INC. FOR A RETURN AUTHORIZATION (RA) NUMBER BEFORE RETURNING THE UNIT FOR REPAIR.



1111 80th Street SW - Suite 250
Everett, WA 98203
p: 425.353.8833
f: 425.353.8390

MAGNUM
E N E R G Y

1111 80th Street SW - Suite 250

Everett, WA 98203

p: 425.353.8833

f: 425.353-8390