

# ME-AGS\* wiring diagram – For Kimpor (KDE Series Diesel Generators)

\* ME-AGS with revision  $\geq 3.2$

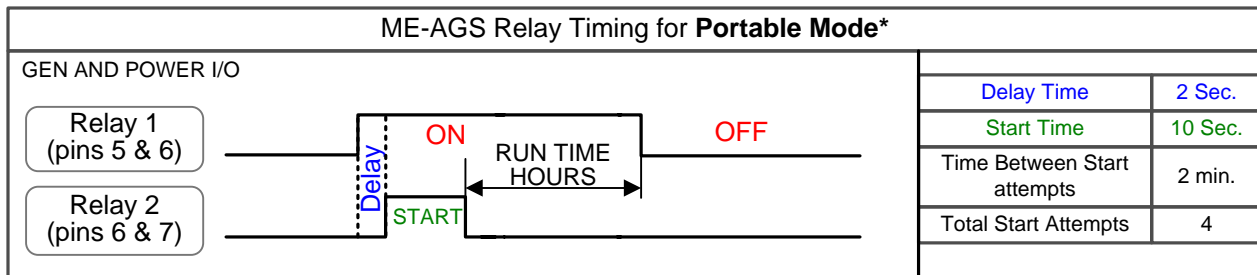
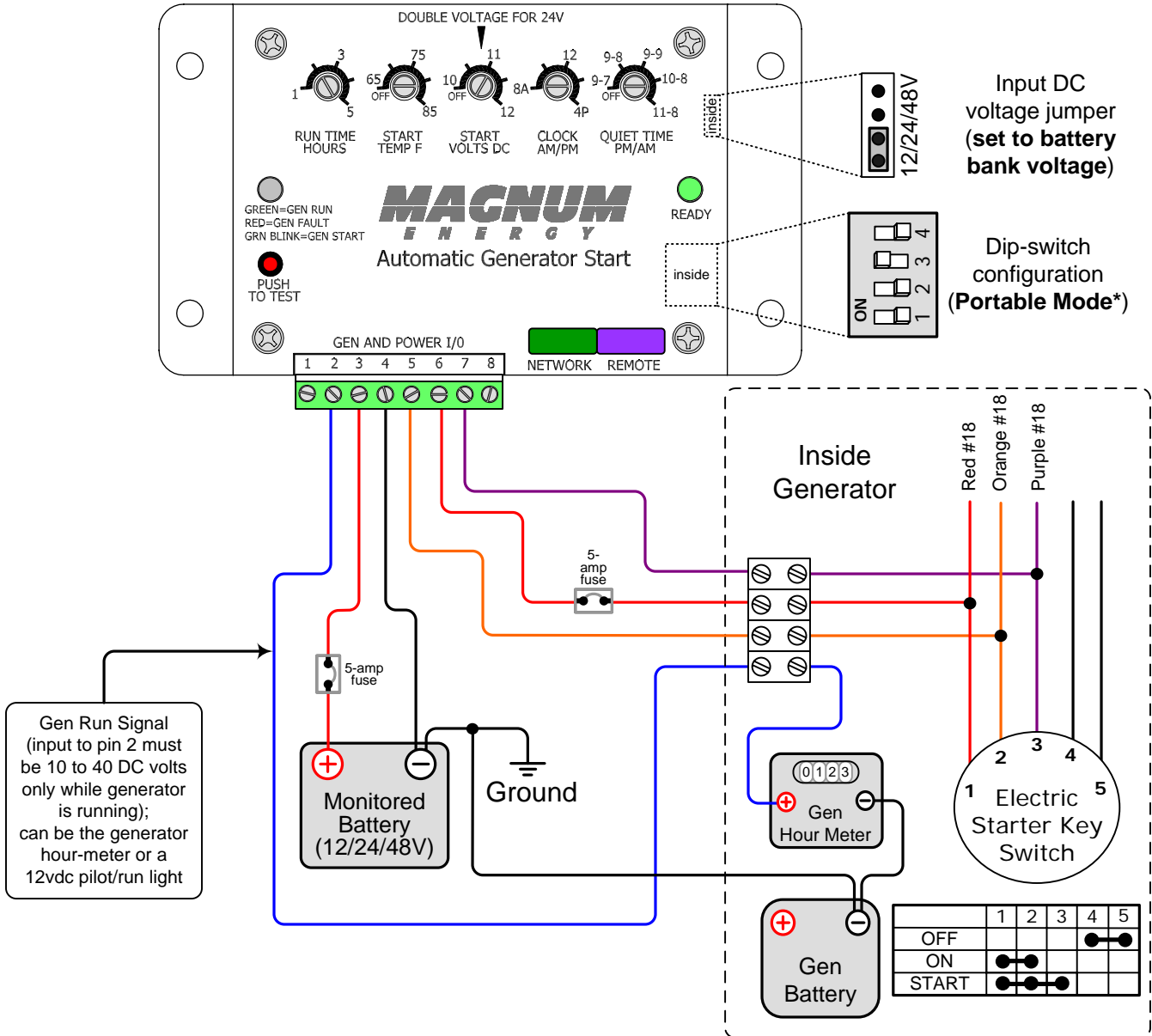

\* to enable Portable Mode, the ME-AGS must be revision 3.2 or higher

Magnum Energy, Inc. provides this diagram to assist in the installation of the Auto-Generator Start controller. Since the use of this diagram and the conditions or methods of installation, operation and use are beyond the control of Magnum Energy, Inc., we do not assume responsibility and expressly disclaim liability for loss, damage or expense arising out of the installation, operation and use of this unit.